

WELCOME TO ONE OF THE WORLD'S MOST ACCESSIBLE HISTORIC SHIPS.

This leaflet helps you plan your visit to Brunel's ss Great Britain and the Brunel Institute. Due to the site's historic nature, some areas may be difficult to access. Where possible, alternative access routes are provided.

We recommend allowing at least two hours for your visit. Please ask staff if you require assistance. Thank you for visiting.

LIFT ACCESS

- Dockyard Museum
- On board ship, access to all deck levels (via the funnel)
- Brunel Institute
- Lifts can accommodate one person in a wheelchair with one person standing, or three people standing
- Each lift operates differently, so please follow instructions

DISABLED TOILETS

- Dockyard Café
- Visitor Centre (ticket office and shop)
- Brunel Institute
- Ground floor, Dockyard Museum
- Lower Saloon Deck on board ship

ASSISTANT OR CARER

- FREE entry for an assistant or carer



DEAF & HARD OF HEARING VISITORS

- British Sign Language (BSL) hand-held interactive video tours are available. Please ask at the ticket office in the Visitor Centre. Pre-booking advised, to avoid disappointment
- BSL video tours for adults, and for children
- Audio loop in the Viridor Theatre in the Brunel Institute



VISITORS WITH LIMITED MOBILITY & WHEELCHAIR USERS

- The Dry Dock, Dockyard Museum, Brunel Institute and the ship are fully accessible for wheelchair users
- Some cabins are too narrow for standard wheelchairs. Please ask at the ticket office in the Visitor Centre for special wheelchairs that fit through cabin doors
- Cobblestones through the main gates are uneven. There is an alternative entrance by the café (please see the site plan)

BLIND & PARTIALLY SIGHTED VISITORS

- Please ask at the ticket office in the Visitor Centre for audio companion tours for blind and partially-sighted visitors, and for the tactile model of the ss Great Britain. Pre-booking advised, to avoid disappointment
- Guide and assistance dogs are welcome
- A sighted assistant is recommended for your visit

'The Access Association has been impressed with the level of commitment given to resolving access issues within this historic dockyard'

Eamon McClelland, past president of the Access Association



Travel by train, cross-harbour ferry, bike or bus (check www.ssgreatbritain.org for details). Satellite navigation: BS1 6TY

Bus routes: The accessible low floor 500 bus runs a regular service. For more information, call 0117 922 4454

P Parking: Disabled parking spaces 90m

Grounds: Tarmac and cobblestone

Dockyard Café, Visitor Centre and Gift Shop: Level access

✉ Brunel's ss Great Britain & the Brunel Institute
Great Western Dockyard
Bristol BS1 6TY

☎ 0117 926 0680

🌐 www.ssgreatbritain.org

BRUNEL'S ss GREAT BRITAIN

Opening times: Open daily, from 10am, except Dec 24 and 25, and 2nd Monday in Jan

Closing times: 5.30pm (British Summer Time) or 4:30pm. Last entry one hour before closing

Group Visits: Welcome, by arrangement

BRUNEL INSTITUTE

See www.brunelinstitute.org for opening times, information and details of formal identification required for entry into the Brunel Institute and David MacGregor library

Available in different formats



The Good Access Guide



- British Sign Language (BSL) video tours
- Audio tours for blind and partially-sighted visitors
- Guide and assistance dogs welcome
- Assistant or carer has free admission
- Wheelchair access

www.ssgreatbritain.org

Reg. charity no. 262158



Great Western Dockyard

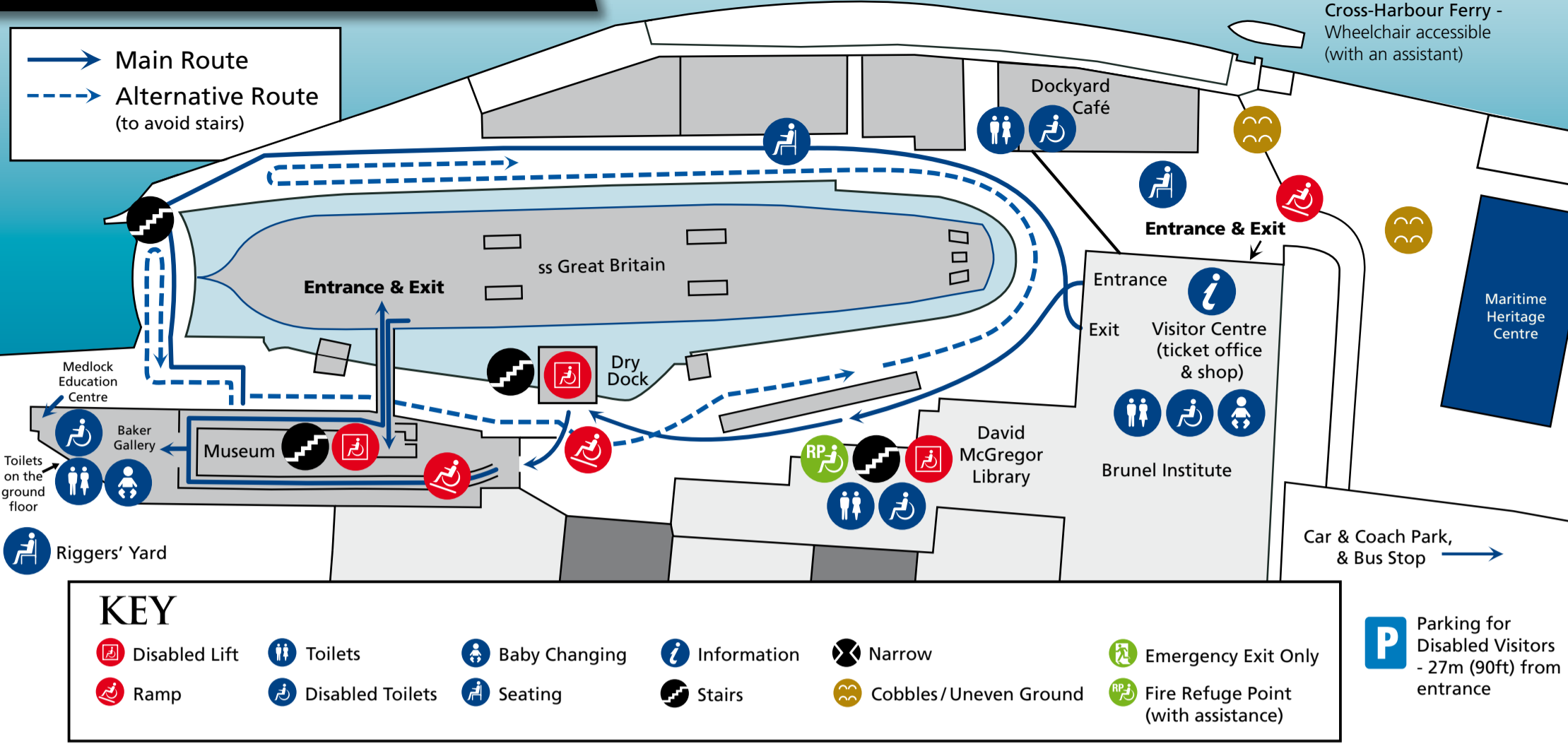

Deck Plans

Weather Deck (top deck)

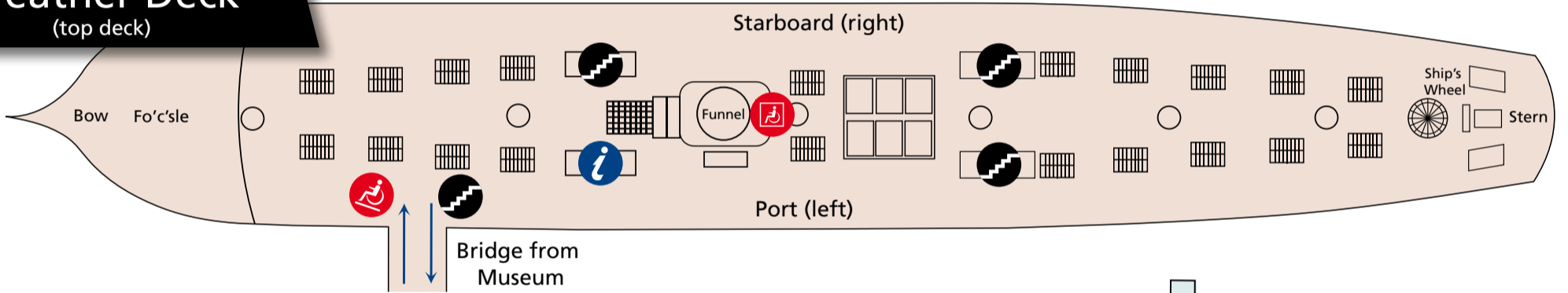

Promenade Deck (middle deck)

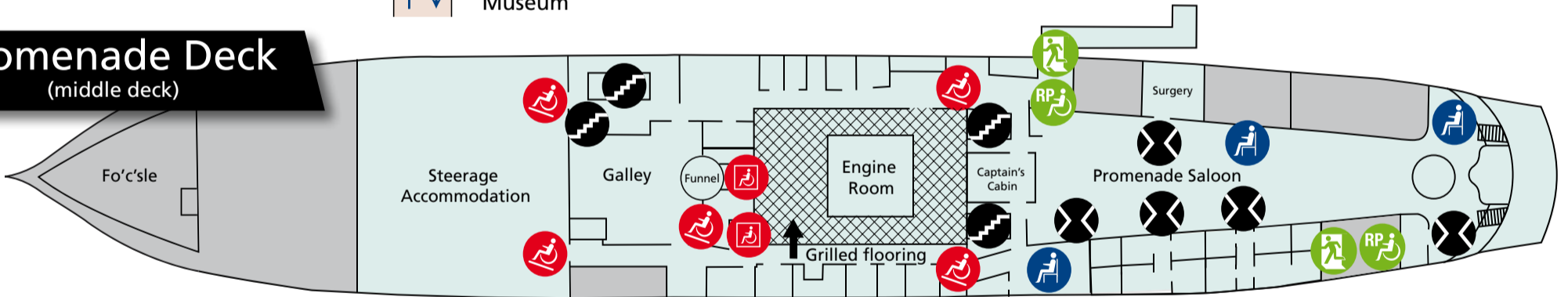

Saloon Deck (lower deck)

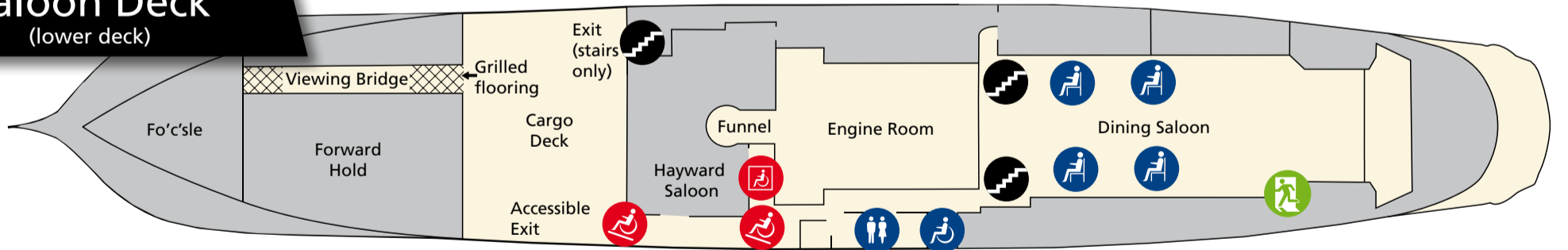

Dry Dock (under the glass 'sea')

